

grind **FAST** at
150 feet per minute....
with enduring precision

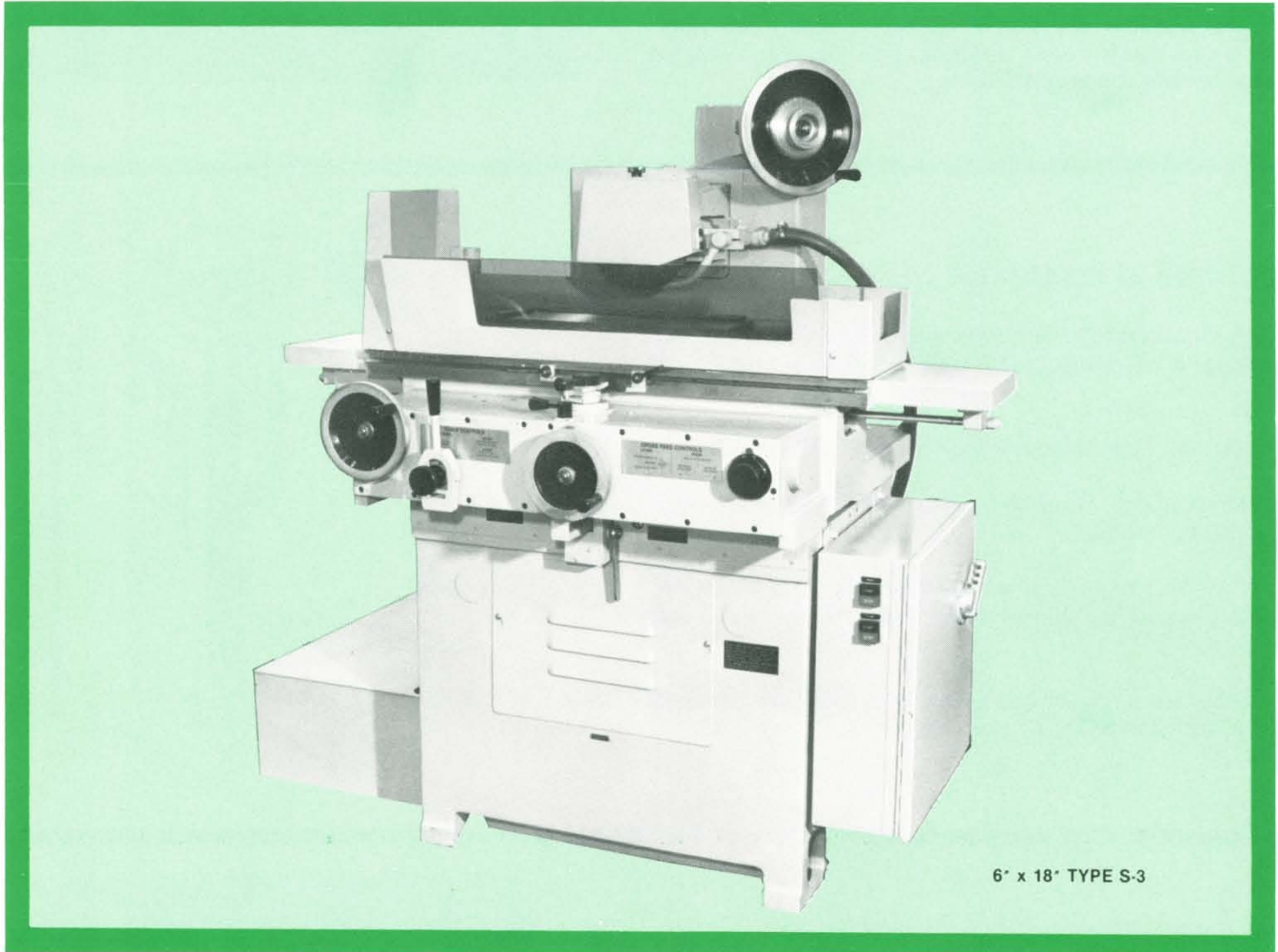

MANUFACTURED IN U.S.A.

Your ability to grind plane surfaces at cost levels that increase your profit-margin is largely the capacity of your equipment to deliver superior performance in:

- Grinding Fast
- Grinding Accurately
- Grinding with Minimum Maintenance

ALLEN

The high speed Allen Type S-3 Hydraulic Surface Grinders give you these important capabilities in a measure that produces extremely sound return on your investment.

S-3 Hydraulic Surface Grinders
6" x 18" and 8" x 24"

grinding accurately

YOU FEED FAST AND ACCURATELY

The Type S-3 allows you to feed fast and accurately in .0001" increments, reading directly from the vertical two-speed hand wheel. This has .0005" graduations for fast positioning and .0001" graduations for precise grinding feeds. The outer wheel is for rapid, coarse settings, and the inner knurled wheel is for fine increment feeding.

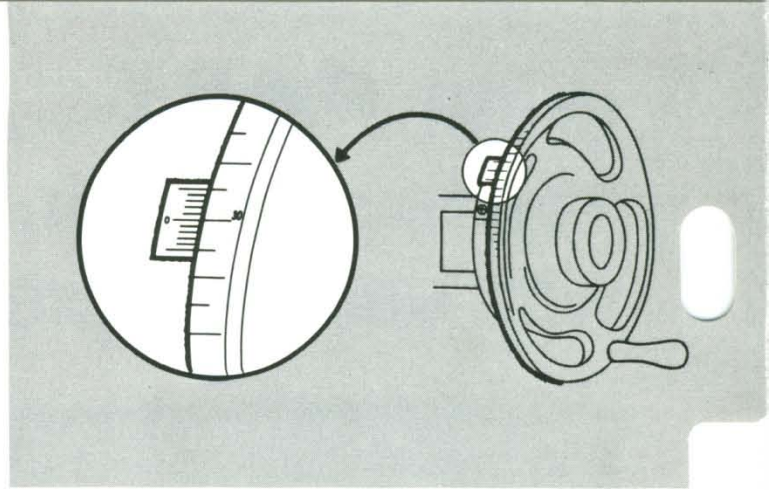

YOU GRIND ACCURATELY

You grind accurately with this machine because of these advantages which assure continued precision in wheel head action:

- Positive, high reduction feed from bevel gears.
- Hang-up free wheel slide with vertical ways performs positive tracking.
- Heavy wheel slide prevents deflection and vibration, eliminates need for excessive caution to obtain fine accuracy.
- Straight tracking of wheel slide with no binding is aided by hand scraped, plain bearing ways.

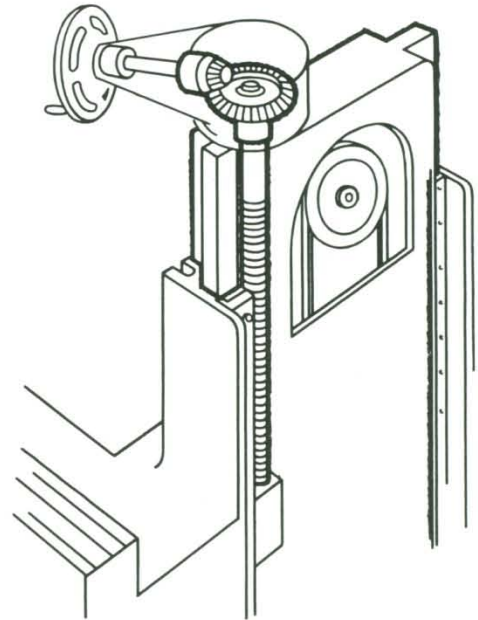

BETTER CROSS FEED ACCURACY FROM GUIDE-RAIL DESIGN

You get better cross feed accuracy from the Type S-3 because of a guide rail of hardened tool steel, attached to the underside of the cross slide at the center. It runs through anti-friction bearing, hardened tool steel rollers attached to the machine base. Improved grinding of parallel shoulders results from this design, which provides direct contact between rollers and guide rail. No oil clearance is required, since the roller bearings are pre-loaded.

The center guide and the two *flat ways* of the cross slide combine to improve grinding of parallel shoulders through straighter "tracking" of the cross slide. For this reason you do parallel shoulder and similar jobs rapidly without painstaking effort.

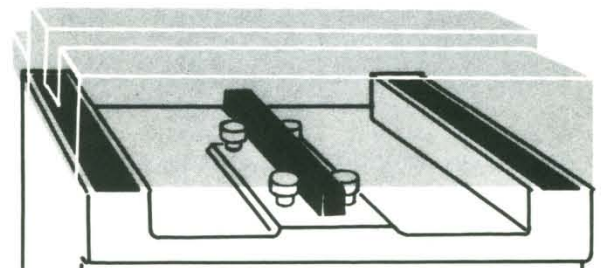

WIDE-SPAN AUTOMATICALLY LUBRICATED WAYS

Long, wide-span, automatically lubricated *flat* cross slide ways over the rigid base walls, aid the grind by increasing machine stability.

The wide center-to-center span of these ways (27" for the 6" x 18" S-3, 33 $\frac{3}{4}$ " for the 8" x 24" S-3), eliminates excessive table overhang and assures a positive, firm support between ways over the complete range. The use of *two* flat ways provides uniform bearing surfaces which prolong grinding accuracy.

here's how
you'll benefit with
your Type S-3

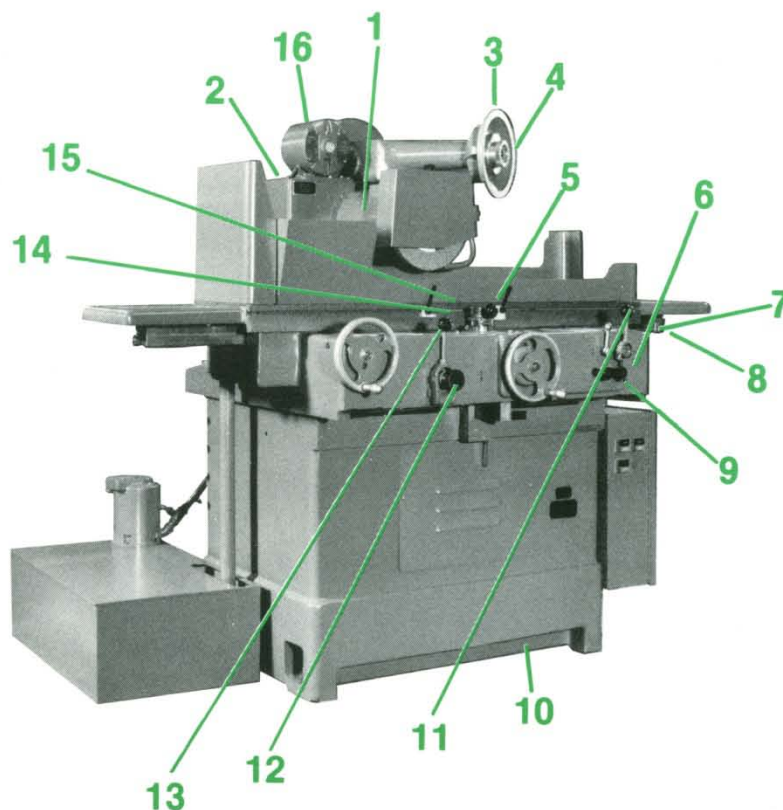

8' x 24' TYPE S-3

- 1 HEAVY OR LIGHT CUTS** — large wheel spindle in heavy-duty housing has extreme rigidity — permits light or heavy cuts with ease.
- 2 COMPLETE WAYS PROTECTION** — Vertical Ways accuracy is extended by protecting ways from grit infiltration by efficient telescoping-type guard.
- 3 TWO-SPEED WHEEL FEED** — large handwheel for rapid positioning and center knurled wheel for reduced fine increment sizing feeds.
- 4 NEW SIZING CONTROL** — fine increment downfeed mechanism, graduated to .0001" increments, gives you smooth positive feed for fine sizing.
- 5 FEATHER-TOUCH REVERSAL** — design of reversal mechanism eliminates hammering of reverse lever on reverse dogs — gives long lasting service.
- 6 POWER WHEEL TRUING** — on the 8' x 24" S-3, the wheel is effortlessly trued by power by operating the cross feed with the work table stationary. Wheel truing on the 6' x 18" S-3 is done by operating the hand cross feed.
- 7 AUTOMATIC WAY LUBRICATION** — table and cross slide ways are automatically lubricated — assuring long, accurate, trouble-free service.
- 8 RAPID CHANGEOVER** — piston rod latches for speedy conversion to hand table traverse. Latches disconnect table from piston rod and eliminate piston drag in cylinder when running by hand.
- 9 INSTANT CROSS FEED SETTINGS** — knob type cross feed adjustment permits fast setting by merely turning knob.
- 10 TOE ROOM** — front base design allows operator to stand close to machine comfortably — especially helpful when handling heavy work pieces.
- 11 FAST CROSS FEED CONTROL** — flip of centralized control changes or stops cross feed direction. Cross feed hand wheel does not turn when in power feed.
- 12 INFINITE NUMBER OF SPEEDS** — hydraulic table traverse quickly adjusted for speeds up to 150 surface feet per minute by simple knob control.
- 13 SIMPLIFIED OPERATION** — separate start-stop and table speed controls permit repeated stops and starts without altering table speed settings.
- 14 ALIGNMENT EASE** — centered reverse lever permits fast dog setting by visual line-up with ends of work pieces.
- 15 SMOOTH TABLE REVERSAL** — design of reversal mechanism and table traverse components eliminates bumping at end of stroke — reversal is cushioned and smooth to further increase working life of machine.
- 16 EFFORTLESS WHEEL HEAD POSITIONING** — fast, fatigue-free wheel head movement is obtained with the Power Wheel Head Positioning Mechanism, available at extra cost. A ¼ h.p. A.C. motor does the work.

SPECIFICATIONS

6" x 18" TYPE S-3

CAPACITY

| | |
|---|------|
| Longitudinal (work) | 18" |
| Longitudinal (maximum table movement)..... | 22" |
| Transverse | 7" |
| Vertical distance, table top to bottom of standard 8" dia. wheel | 15½" |
| Vertical movement of wheel head | 16¾" |

WORK TABLE

| | |
|------------------------------|-----|
| Width of work surface | 6" |
| Length of work surface | 18" |
| Tee slots—standard ½" | 3" |

SPINDLE

Antifriction Bearing Spindle, Cartridge Type,
Flat or Vee belt drive, speed, r.p.m. 2750

GRINDING WHEELS

Type..... No. 1 (straight)
Belt drive spindle 8" x ½" to ¾" x 1¼"

TABLE TRAVEL

Hydraulic power — (feet per minute) variable,
up to 150 feet per minute
Hand table traversing mechanism also provided — one revolution of hand wheel
moves table 3-1/8"

FEEDS

Vertical:
Vernier graduated0001"
Hand wheel graduated0005"
Cross Feed Hand Wheel Graduated..... .001"
(Each graduation represents .001" or .0264 mm.)
Cross Feed: Automatic at each reversal;
adjustable from 0" to .100" (approx.)

DRIVE

Grinding Wheel
2 h.p. constant speed motor
(60 cycle speed is 1800 r.p.m. — 50 cycle
speed is 1500 r.p.m.)
Flat or vee belt drive to spindle
Hydraulic Pump
2 h.p. constant speed motor
(60 cycle speed is 1800 r.p.m. — 50 cycle speed
is 1500 r.p.m.)

WEIGHTS (Approximate)

| | |
|-------------------------|-----------|
| Net | 2850 lbs. |
| Domestic shipping | 3100 lbs. |
| Export shipping | 3250 lbs. |

8" x 24" TYPE S-3

CAPACITY

| | |
|--|------|
| Longitudinal (work) | 24" |
| Longitudinal (maximum table movement)..... | 28" |
| Transverse | 9" |
| Vertical distance, table top to bottom of standard 10" dia. wheel | 13¾" |
| Vertical movement of wheel head | 15½" |

WORK TABLE

| | |
|--------------------------------|-----|
| Width of work surface | 8" |
| Length of work surface | 24" |
| Tee slots—standard 9/16" | 3" |

SPINDLE

Antifriction Bearing Spindle, Cartridge Type,
Vee belt drive, speed, r.p.m. 2270

GRINDING WHEELS

Type..... No. 1 (straight)
Standard Size 10" x 1" x 3"

TABLE TRAVEL

Hydraulic power — (feet per minute) variable,
up to 150 feet per minute
Hand table traversing mechanism also provided — one revolution of hand wheel
moves table 3-1/8"

FEEDS

Vertical:
Vernier graduated0001"
Hand wheel graduated0005"
Cross Feed Hand Wheel Graduated..... .001"
(Each graduation represents .001" or .0264 mm.)
Cross Feed: Continuous for truing, or
Automatic at each reversal;
adjustable from 0" to 3/16"

DRIVE

Grinding Wheel
3 h.p. constant speed motor
(60 cycle speed is 1800 r.p.m. — 50 cycle
speed is 1500 r.p.m.)
Vee belt drive to spindle (Flat belt optional)
Hydraulic Pump
2 h.p. constant speed motor
(60 cycle speed is 1800 r.p.m. — 50 cycle speed
is 1500 r.p.m.)

WEIGHTS (Approximate)

| | |
|-------------------------|-----------|
| Net | 3700 lbs. |
| Domestic shipping | 4000 lbs. |
| Export shipping | 4450 lbs. |

(Because of variations in equipment and castings exact weights cannot be given. Motors and magnetic chuck weights are included in approximate weights.)

The description, illustrations and specifications in this booklet are correct at the time of printing. Machines built at later dates may differ in detail due to the policy of Chas. G. Allen Co. Incorporated to improve its machines constantly.

For factory direct replacement parts and service contact us at the address below.